

Channel Quality Improvement for BER using Different Channel Estimation Techniques for OFDM Systems

Rajeshwar Singh, Gurpreet Singh Saini

Abstract---In this paper we present an improved and robust channel estimation algorithm for OFDM mobile communication systems based on the use of pilot subcarriers. Specifically we present an iterative channel estimation technique to improve the performance of channel estimators. In iterative receiver structures, soft information becomes available after the decoding stage. This information is used to enhance the quality of the channel estimates for the next iteration. The low complexity proposed receiver including LMS algorithm, has a higher efficiency than conventional methods (without channel estimation, LS & LMMSE) and it can work in lower amount of SNRs. We derive a generalized estimator based on the linear minimum mean square error (LMMSE) principle for deterministic pilot information combined with soft information. The performance is presented in terms of Bit-error rate (BER) for a system using 16-quadrature amplitude modulation (QAM). Simulation results validate that the proposed channel estimation scheme can achieve tremendous performance as the existing channel estimation methods.

Keywords—Channel estimation (CE), OFDM (Orthogonal Frequency Division Multiplexing), LS (Least Square), LMMSE (Linear Minimum Mean Square Error), LMS (Least Mean Square), QAM (Quadrature Amplitude Modulation).

1. INTRODUCTION

Worldwide Interoperability for Microwave Access (WiMAX) is a promising technology that was predicted to be the great leap toward broadband metropolitan area wireless network. This technology is specified in IEEE std. 802.16 in which OFDM, OFDMA techniques are used as modulation methods. In the recent years there has been a lot of interest in applying Orthogonal frequency division multiplexing in wireless and mobile communication systems because of its high rate transmission capability with high bandwidth [4]-[5] efficiency and robustness to multipath fading and delay. OFDM based systems are strong candidates for air interface of future fourth generation mobile wireless systems which provides high data rate and mobility.

In order to achieve the potential advantages of OFDM based systems, the channel coefficients should be estimated with minimum error. Then these estimates are interpolated over the entire frequency-time grid using 2D or two 1D Wiener filtering [6]. These estimation methods are performed assuming the statistical properties of the channel are perfectly known at the receiver side.

- *Rajeshwar Singh is currently pursuing masters degree program in electronic and communication engineering in Lovely Professional University, INDIA, PH-+919803416878. E-mail: Rajeshwar.singh40@gmail.com*
- *Gurpreet Singh Saini is currently Asst. Professor in the Department of*

electronics and communication engineering in Lovely Professional University, INDIA, PH-+919914954471. E-mail: gurpreet16889@lpu.in

To estimate the channel coefficients and correct received signal, the pilot based approach [2]-[3] is inserted in frequency, are widely used in which pilot subcarriers are inserted at the transmitter side and channel coefficients that belong to the pilot subcarriers are estimated using the LS (Least Square) method.

Channel estimation can be improved using more pilot symbols but it causes data rate reduction or bandwidth expansion [6]. Therefore in this case iterative techniques provide an improvement on the channel estimator performance without requiring additional pilots. The idea is to feed back information from the output of the channel decoder to the estimation stage. The estimator can improve its performance because it gets not only the information from the pilots but also reliability information of the coded bits.

In this paper we consider pilot symbol aided iterative channel estimation method for OFDM based systems using the LMS technique. We evaluate the estimation accuracy of the proposed estimation method and bit error rate performance of the proposed system. The proposed system with LMS technique provide better results for bit error rate as compared to the MMSE and LS channel estimators. The MMSE estimator has good

performance but high complexity. The LS estimator has low complexity but its performance is not as good as that of MMSE estimator. So in this case iterative LMS technique provide better results with less complexity.

2. SYSTEM DESCRIPTION

2.1 System Model

In this section we will examine the transmitter and receiver structure of OFDM systems including the pilot distribution. Then we will describe the pilot symbol aided channel estimation techniques with the DFT based interpolation in frequency axis and linear interpolation in time axis.

We will consider the system as illustrated in Figure 1, the vector of data bits is first encoded with an error correcting code such as convolutional code to obtain the vector of coded data bits. This vector is mapped accordingly to the constellations and vector of data symbols is obtained. After the guard band is inserted, an N-point Inverse Discrete Fourier Transform (IDFT) block transforms the data sequence into time domain. Following the IDFT block, a cyclic extension of time length T_g chosen to be larger than the expected delay spread is inserted to avoid Inter Symbol Interference (ISI) [7-10]. The Digital to Analog Converter (D/A) contains low pass filters. The channel is modeled as an impulse response $h(t)$ followed by the complex additive white Gaussian Noise $\omega(t)$ as shown in figure 1.

$$h(t, \tau) = \sum_{m=1}^M \alpha_m(t) \delta_D(\tau - \tau_m(t)),$$

where $\tau_m(t)$ and $\alpha_m(t)$ are the delay and the complex amplitude of the m^{th} path, respectively.

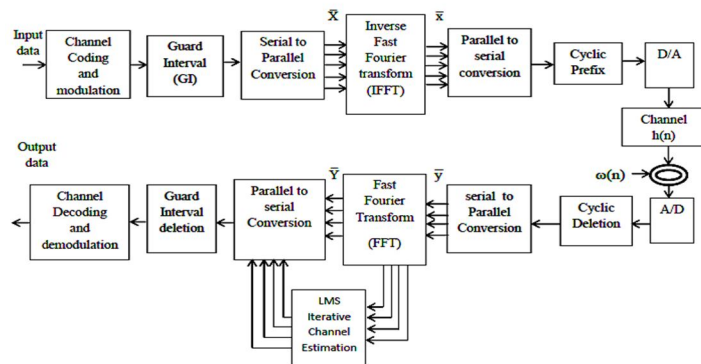

Where,

\bar{x} =OFDM symbol ω =Additive White Gaussian Noise
 h =Channel transfer function \bar{Y} =Received signal

Figure 1 A digital implementation of OFDM Baseband System

For pilot symbol aided channel estimation, pilot symbols are inserted periodically with the particular distances in frequency and time grid. The two basic 1-D channel

estimations in OFDM systems are illustrated in Figure 2. The first one is, block type pilot channel estimation, is developed under the assumption of slow fading channel and is performed by inserting pilot symbols within a specific period. The second one, comb-type pilot channel estimation is introduced to satisfy the need for equalizing when the channel changes even from one OFDM block to the subsequent one and it is performed by inserting pilot subcarriers of each [6] OFDM symbol where the interpolation is needed to estimate the condition of data subcarriers.

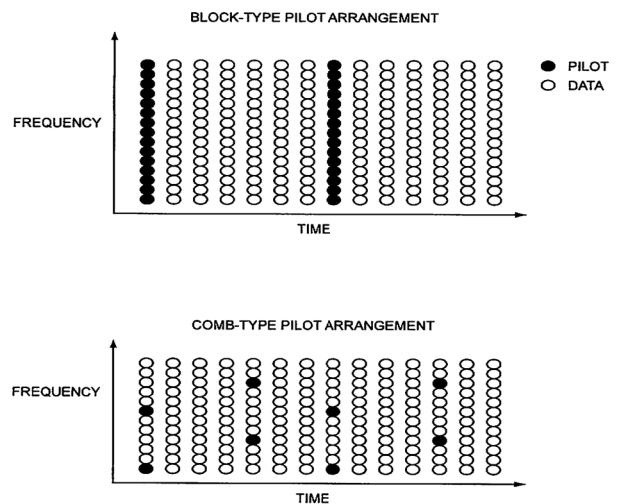

Figure 2 Types of Pilot insertion in OFDM systems

Symbol Vector (\bar{x}) is converted to the transmitted vector (\bar{x}) with length $K*N$ by a serial to parallel converter where K is the number of total subcarriers in one OFDM symbol and N is total number of OFDM symbols in frame. Each OFDM symbol vector in the frame $\bar{x}=[x(n)]=[x_1(n), x_2(n), x_3(n), \dots, x_k(n)]$ is modulated into K subcarriers by an IFFT and then Guard interval (GI) is inserted. Then OFDM frame is transmitted through the time varying frequency selective channels. This channel is described using baseband equivalent impulse

response as $\bar{h}=[h(n)]=[h1(n),h2(n),h3(n),\dots,h_l(n)]$ where l is the length of channel. We assume $\bar{n} = [\omega(n)]=[\omega1(n), \omega2(n), \omega3(n),\dots, \omega_c(n)]$ as additive white Gaussian noise added over channel. Define the input matrix:

$$F = \begin{bmatrix} W_N^{00} & \dots & W_N^{0(N-1)} \\ \vdots & \ddots & \vdots \\ W_N^{(N-1)0} & \dots & W_N^{(N-1)(N-1)} \end{bmatrix}$$

Here, $W_N^{n,k} = \frac{1}{\sqrt{N}} e^{-j2\pi nk/N}$ is called twiddle factor.

Also define $H=DFTn(\bar{h})=F\bar{h}$ and $N=F\bar{n}$

After removing the Cyclic prefix and applying FFT, the received signal is obtained as,

$$Y = DFT(IDFT(X^* \bar{h} + \bar{n})) \quad (1)$$

The system described by (1) can be written as a set of N independent gaussian channels as shown in figure (3)

$$Y_k = H_k X_k + N_k \quad (2)$$

Where $k=0,1,2,3,\dots,N-1$

As a matter of convenience we write (2) in matrix notation:

$$Y = XH + N \quad (3)$$

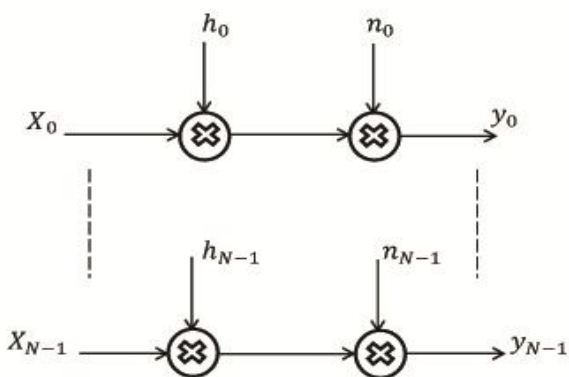

Figure 3: Parallel Gaussian channels

In the channel estimation unit, the estimate of H is obtained with the channel information given by H , channel equalization is performed by $X = Y/H$. Finally X is demodulated and original signal is restored.

2.2 Pilot Aided Channel Estimation

In pilot aided channel estimation scheme, pilot symbols are added at the transmitter side in which all subcarriers are used as pilots. If we assume that channel is constant then there will no channel estimation error since the pilots are sent at all carriers. The estimation can be performed by two methods. The first one is LS (Least Square) and the second one is MMSE (Minimum Mean Square Error).

LS Estimator

The first step in the channel estimation process is to remove the modulation of the pilot symbols. Thus an initial estimate of the CTF (Channel Transfer Function) at pilot positions is obtained. The estimate of [12] channel transfer function is obtained by using LS estimator. The LS estimate is represented by:

$$\hat{H}_{LS} = X^{-1} Y$$

Which minimizes the parameter :

$$(Y - XH)^H (Y - XH)$$

LS estimators are calculated with very low complexity, but they suffer from a high mean-square error.

MMSE Estimator

If the time domain channel vector h is Gaussian and uncorrelated with the channel noise ω , the frequency domain MMSE [12-13] estimate of h is given by:

$$\hat{H}_{MMSE} = FRH Y R_{yy}^{-1} Y$$

Where,

$$R_{HH} = E\{HH^H\} = E\{(Fg)(Fg)^H\} = FR_{gg}F^H$$

$$R_{gy} = E\{g^H Y^H\} = E\{g^H (XFg + N)^H\} = R_{gg}F^H X^H$$

$$R_{YY} = E\{Y^H Y\} = XFR_{gg}F^H X^H + \sigma^2 I_N$$

R_{hy} is the cross covariance matrix between h and y and R_{YY} is the auto covariance matrix of Y . R_{HH} is the autocovariance matrix of H and σ^2 represents the noise variance $E\{|W(k)|^2\}$. The MMSE estimator yields much better performance than LS estimators especially under

the low SNR scenarios. A major drawback of the MMSE estimator is its high computational complexity, especially if matrix inversions are needed each time the data in X changes.

2.3 Proposed Iterative Channel Estimation

In order to improve the channel estimation accuracy we provide iterations to the estimated channel. The channel which was estimated in each iteration would be used for next iteration.

Channel information is required at receiver for signal detection. There are a large number of methods to obtain initial estimation and many iterative algorithms to improve the performance of estimation. We know that pilot symbols are inserted at the transmitter side in order to obtain estimate of the channel at the receiver side. This estimation in each iteration can be used as side information and feed back to system to achieve better result for next iteration. [14-15]

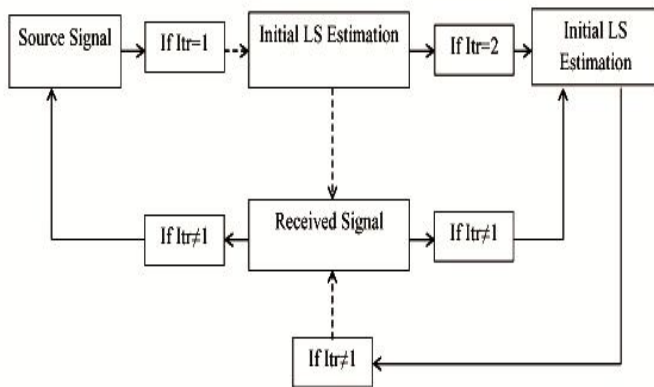

Figure 4 :Implementing LMS Iterative algorithm

The iterative algorithm which is used in this paper is LMS algorithm that uses channel estimation of last iteration that helps to improve the results in next iteration.

It is given by:

$$\hat{H}_n = \hat{H}_{n-1} - \mu e^* X$$

Where,

- n = The iteration state
- e = The signal error
- μ = A coefficient between 0-1

We apply the number of iterations until the determined criteria will be reached, which it could be a special MSE. As illustrated in figure 4, LMS algorithm is applied to receiver and the channel which was estimated in each iteration would be used for next iteration additionally the output signal is fed to source signal for next channel estimation. Another important factor in channel estimation through this method is μ which influences on estimation and should be precisely chosen. The performance of LMS algorithm can be closely to LS algorithm by careful choice of μ .

3. SIMULATION AND EVALUATION

In this section we demonstrate the performance of proposed iterative channel estimation method for OFDM systems. In the simulation we consider an OFDM system operating with bandwidth of 8.75 MHz, Length of FFT as 1024 and Guard Interval of 1/8. Total number of data bits are inserted uniformly at even and odd positions. System parameters used in the simulation are indicated in Table 1.

Parameters	Values
System bandwidth	8.75MHz
Sampling Frequency	10 KHz
Number of subcarriers	1024
Cyclic prefix	1/8
Modulation	16 QAM
Useful symbol Time	0.1024ms
OFDM Symbol Time	0.1152ms
Guard Time	0.0128ms=12.8us

Table 1. OFDM system parameters

In the simulation we present 16 QAM modulation scheme. Total number of data bits taken are 1024 and 3456 OFDM symbols. The generation of modulated OFDM data symbols is illustrated in Figure 5:

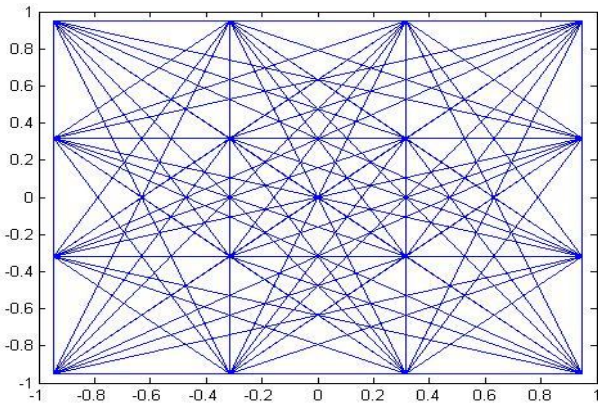

Figure 5: Modulated OFDM data symbols

The equispaced pilot symbols and data are now constructed in the OFDM frame at even and odd positions. Pilot symbols can be viewed as shown in figure 6.

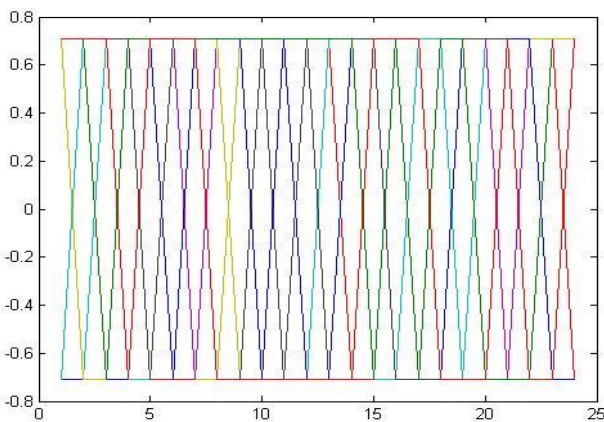

Figure 6: Pilot symbols representation.

And data symbols can be viewed as,

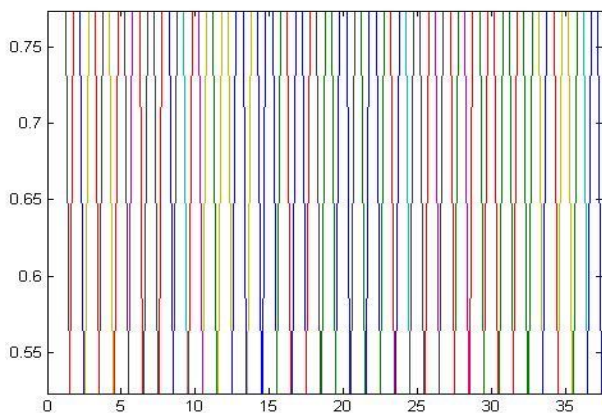

Figure 7: Data symbols representation

Both Pilot symbols and data symbols constructed in OFDM frame is shown in figure 8:

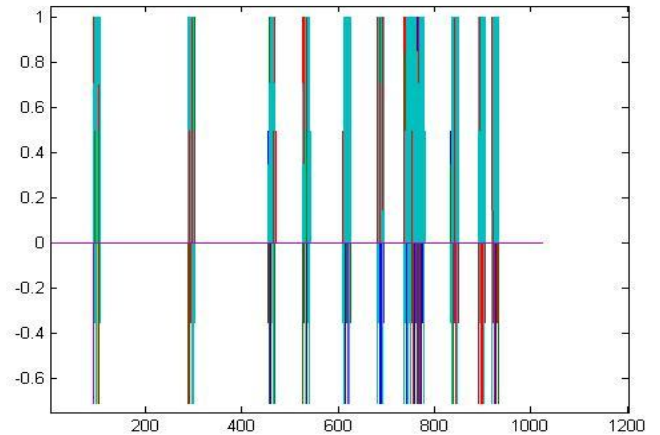

Figure 8: Data and pilot representation in OFDM frame

The formation of OFDM frame can be seen as shown in figure 9:

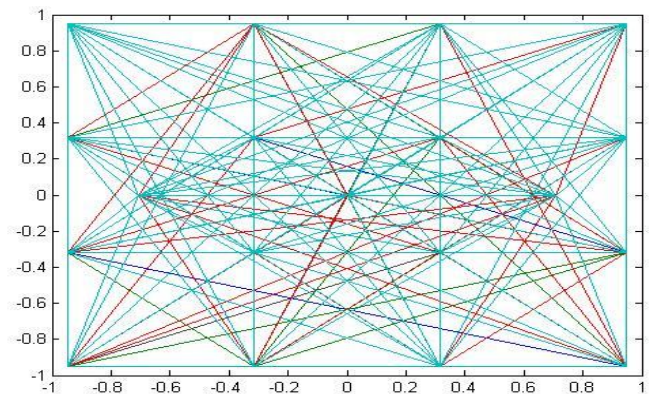

Figure 9: Formation of OFDM frame

The next process in OFDM signal generation is taking the Inverse Fast Fourier Transform which converts the data in time domain. After that Cyclic Prefix is inserted which is responsible to avoid inter symbol interference. CP=1/8 is taken in the simulation process. In this paper 128 bits of cyclic prefix is inserted in OFDM frame. Finally we do reshaping of resultant data.

The data is received after passing through Rayleigh channel model and additive White Gaussian Noise is added to the channel. At the receiver side we proposed LMS Iterative Algorithm which takes the result of last

iteration as a feedback to the system and helps to improve the channel estimation performance by reducing the Bit Error Rate. As we apply more number of iterations that will lead to reduce more Bit Error Rate whose performance can be seen from Table 2. In which LMS proves its efficiency as compared to No channel estimation, LS (Least Square) and LMMSE (Linear Minimum Mean Square Error) as shown in the following results from figure 10 to figure 13.

Table 2. shows the performance of OFDM system using LMS iterative algorithm between Bit Error Rate and Signal to Noise Ratio. Table shows LMS iterative algorithm upto 4 iterations.

Following graphs shows the performance of LMS iterative algorithm Upto four iterations which shows that LMS iterative algorithm performs better results than LS and LMMSE algorithms.

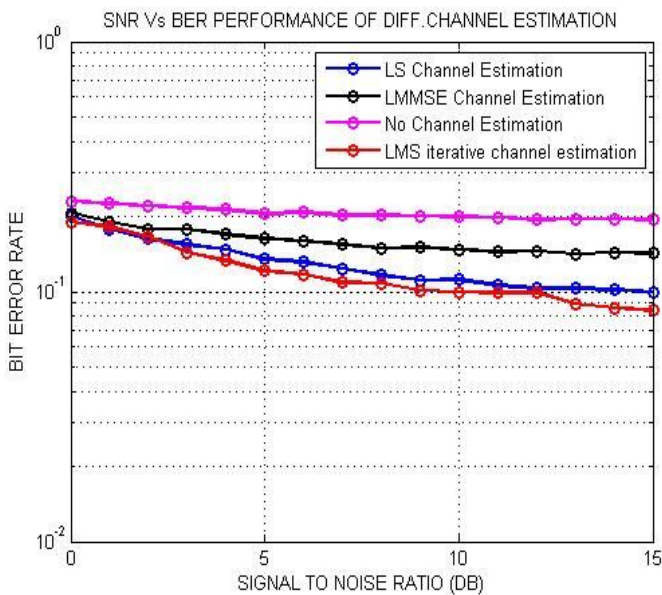

Figure 10 :Simulation results with iteration = 1

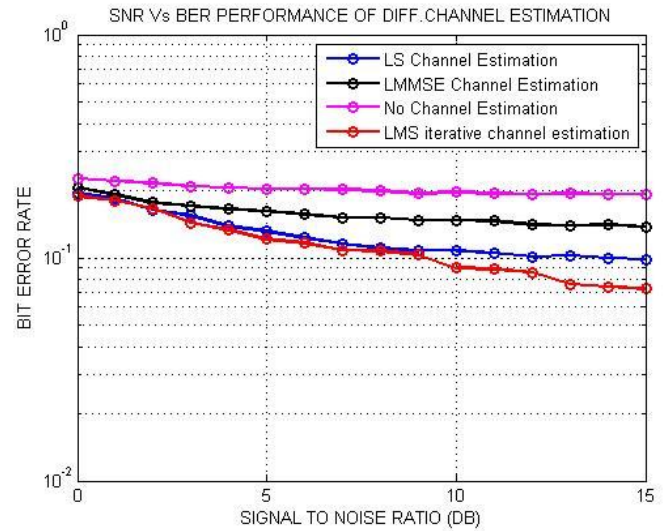

Figure 11 :Simulation result with iteration=2

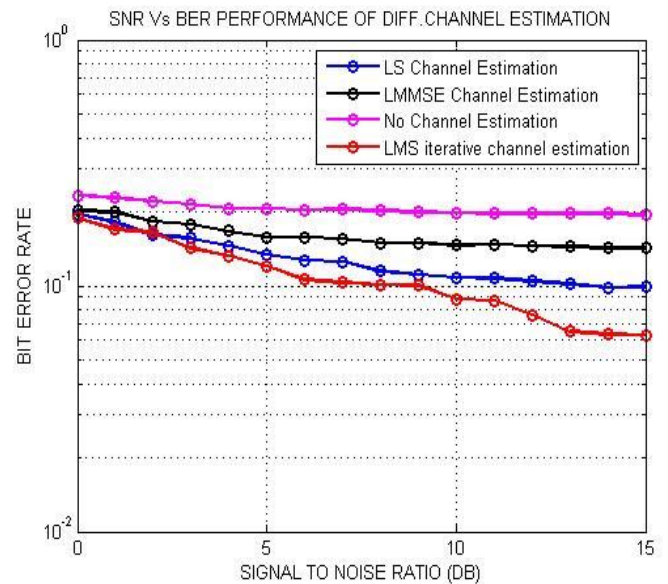

Figure 12 :Simulation result with iteration=3

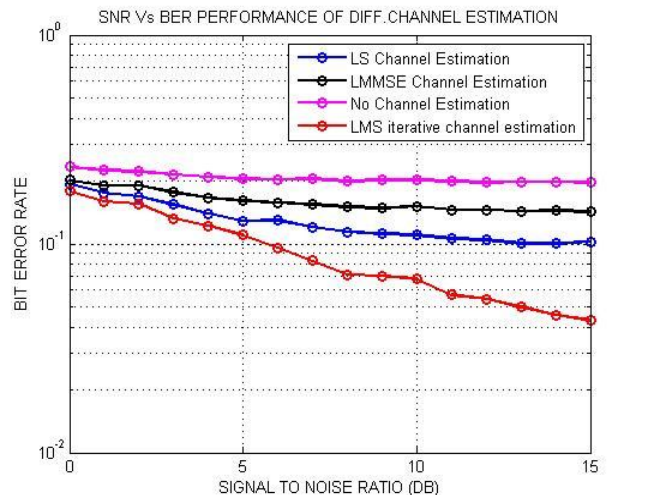

Figure 13 :Simulation result with iteration=4

Table 2: BER Vs SNR for LMS Channel Estimation Technique with different iterations

4. CONCLUSION

In this paper we proposed a receiver structure with low complexity. To improve the performance of receiver structure an efficient LMS iterative algorithm is added with the receiver, which includes the side information in each iteration as a feedback to the system to improve the BER performance of the system close to the ideal channel performance. LMS algorithm has a higher efficiency than conventional methods and it can work in lower amount of SNR. As we apply more number of iterations, BER reduces with increasing SNR value.

REFERENCES:

[1] H. Sari, G. Karam, and I. Jeanclaude. Transmission techniques for digital terrestrial TV broadcasting. *IEEE Communications Magazine*, 33(2):100-109, 1995.

[2] ETSI EN 302 304 Digital Video Broadcasting (DVB); transmission system for handheld terminals (DVB-H). European Telecommunication Standard, November 2004.

[3] Ye. Li, "Pilot-symbol-aided channel estimation for OFDM in wireless systems," *IEEE Trans. Veh. Technol.*, vol. 49, no. 4, pp. 1207-1215, 2000

[4] D. K. Borah and B. T. Hart, "Frequency-selective fading channel estimation with a polynomial time-varying channel model," *IEEE Trans. Commun.*, vol. 47, no. 6, pp. 862-873, 1999

[5] D. Slock, "Signal Processing challenges for wireless Communication," in Proc. 1st Int. Sym. on Control, Communications and Signal Processing, Tunisia, March 21-24 2004, pp. 881-892.

[6] P. Hoeher, S. Kaiser and I. Robertson, "Two dimensional pilot-symbol-aided channel estimation by Wiener Filtering," in Proc. *IEEE ICASSP'97*, pp. 1845-1848, April 1997.

[7] Ottersten, B., Viberg, M., and Kailath, T., "Performance Analysis of the Total Least Squares

ESPRIT Algorithm," *IEEE Transactions on Signal Processing*, vol. 39, pp. 1122-1135, May 1991.

[8] Hou, X., Li, S., Liu, D., Yin, C., and Yue, G., "On Two-dimensional Adaptive Channel Estimation in OFDM Systems," *60th IEEE Vehicular Technology Conference, Los Angeles, Ca.*, vol. 1, pp. 498-502, Sept.

SNR	BER(Bit Error Rate)			
	ltr=1	ltr=2	ltr=3	ltr=4
1	0.1828	0.1779	0.17	0.16
2	0.1668	0.162	0.1673	0.155
3	0.1435	0.143	0.142	0.132
4	0.1335	0.133	0.132	0.122
5	0.1215	0.121	0.12	0.11
6	0.1169	0.116	0.106	0.096
7	0.1089	0.108	0.103	0.083
8	0.1081	0.1071	0.101	0.071
9	0.1008	0.103	0.1001	0.07
10	0.0998	0.0898	0.088	0.068
11	0.0991	0.0891	0.0871	0.0571
12	0.0989	0.0859	0.0759	0.0545
13	0.0893	0.0763	0.0653	0.0498
14	0.0859	0.0739	0.0635	0.0455
15	0.0845	0.0725	0.0629	0.0429

2004.

[9] Sanzi, F., Sven, J., and Speidel, J., "A Comparative Study of Iterative Channel Estimators for Mobile OFDM Systems," *IEEE Transactions on Wireless Communications*, vol. 2, pp. 849-859, Sept. 2003.

[10] Li, Y., "Simplified Channel Estimation for OFDM Systems with Multiple Transmit Antennas,"

IEEE Transactions on Communications, vol. 1, pp. 67-75, January 2002.

[11] J. J. van de Beek, O. Edfors, M. Sandell, S. K. Wilson, and P.O. Börjesson, "On channel estimation in OFDM systems," in Proc. *IEEE Vehicular Technology Conf.*, vol. 2, Chicago, IL, July 1995, pp. 815-819.

[12] Coleri, S., Ergen, M., Puri, A., and Bahai, A., "Channel Estimation Techniques Based on Pilot

Arrangement in OFDM Systems," *IEEE Transactions on Broadcasting*, vol. 48, pp. 223-229, Sept. 2002.

[13] Louis L. Scharf, Statistical Signal Processing, Addison-Wesley, 1991

[14] Chen, J., C. Chiang and L. Lo, 2007. Iterative Channel Estimation for MIMO OFDM Systems. Proceeding of the International Symposium on Intelligent Signal Processing and Communication Systems, Nov. 28-Dec. 1, *IEEE Xplore Press, Xiamen*, pp: 774-777. DOI: 10.1109/ISPACS.2007.4446002.

[15] Qiao, Y., S. Yu, P. Su and L. Zhang, 2005. Research on an iterative algorithm of LS channel estimation in MIMO OFDM systems. *IEEE Trans. Broadcast.*,51: 149-153. DOI: 10.1109/TBC.2004.842524

BIBLIOGRAPHY:



Rajeshwar Singh is M.Tech. student in the Department of Electronics and communication at Lovely Professional University Phagwara, Punjab. He received his B.Tech. from same University in September 2011. He has worked as an engineer in Airtel Telecom for 6 months. His research interests include communication theory and Ad-hoc networks.

Contact No: +919803416878



Mr. Gurpreet Singh Saini received his M.Tech. degree from Lovely Professional University in 2012 and worked as an engineer in AIRTEL TELECOM 6 months. Since January 2012, he has been with same University as a Asst. Professor. He has published one national and one international journal in Wimax technology. His interest lies in enhancing Mobile Wimax technology with channel estimation algorithms and protocols of Mobile Ad-hoc networks.